



A TECHNICAL WHITE PAPER ON THE
CAS IN-WALL LOUDSPEAKERS

 **Infinity**[®]
TECHNOLOGY • PERFORMANCE • DESIGN

THE CAS SERIES SETS A NEW STANDARD FOR IN-WALL-LOUDSPEAKER PERFORMANCE. SEVERAL UNIQUE PROBLEMS HAD TO BE SOLVED IN ORDER TO PROVIDE THE EXCELLENT SOUND THAT, UNTIL NOW, WAS ONLY AVAILABLE FROM MORE CONVENTIONAL BOOKSHELF OR FLOORSTANDING SPEAKERS.

REDUCING UNWANTED RESONANCES

Our goal at Infinity is to eliminate unwanted resonances from all our loudspeakers. In the case of in-wall speakers, these unwanted resonances can come from several sources: the drivers themselves, the wall in which the speaker is installed and the baffle to which the drivers are mounted. The CAS Series utilizes several new and innovative technologies to dramatically reduce these unwanted resonances, resulting in cleaner, more natural sound reproduction.

THE BAFFLE ISOLATION SYSTEM

Wall resonance is generally caused by two things. One is by sound emanating from the back of the loudspeaker bouncing around the inside of the wall cavity. Filling the wall with a suitable damping material, such as fiberglass, helps to minimize this problem. The second – and more difficult problem to solve – results from the energy transfer caused by the mechanical coupling of the loudspeaker to the wall. Infinity's Baffle Isolation System is a compliant suspension system that "floats" the baffle within the mounting frame and greatly reduces the energy transfer to the mounting frame and, in turn, the wall. (Cutaway illustration at right shows the isolation assembly.) Four of these assemblies – one at each corner of the baffle – form the isolation system. These assemblies reduce unwanted mechanical coupling in much the same way the suspension system of a car isolates the passenger cabin from road vibration. Figure 1 compares motion of a typical wall with and without the Baffle Isolation System. Mechanical energy transmission to the wall is reduced by as much as 12dB!

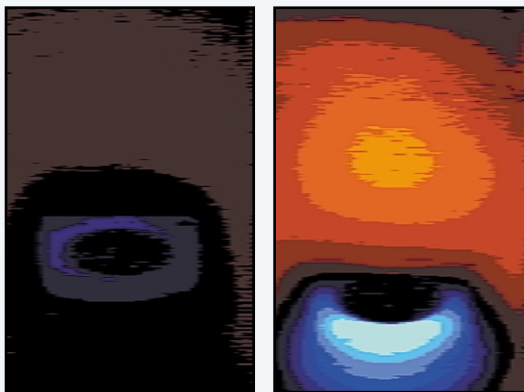
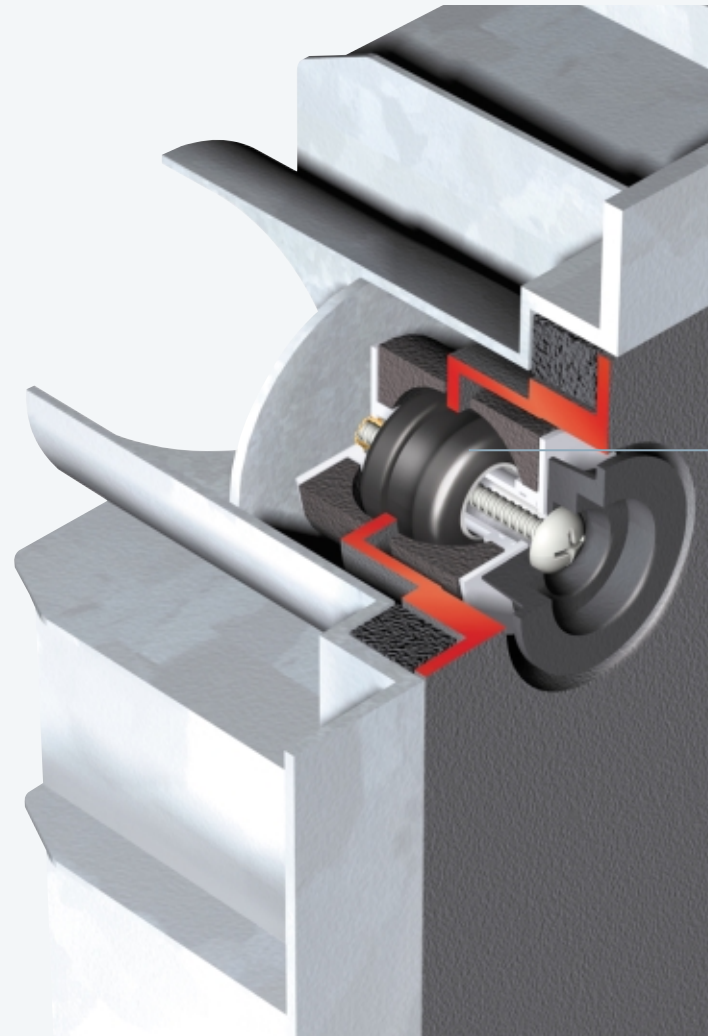

Figure 1: Scanning laser vibrometer measurement of wall-panel resonance with an in-wall loudspeaker playing.

Note: More extreme colors indicate increased wall vibration.

With the Baffle Isolation System

Without baffle isolation

NORYL® BAFFLE AND CAST-ALUMINUM WOOFERS

The baffle of in-wall speakers is typically made of ABS plastic, which is prone to flexing. Yet another resonance for our engineers to tame! After exhaustive research, a two-part solution was chosen. First, the CAS baffles were constructed of Noryl, a high-stiffness thermoplastic resin. Noryl is 40% stiffer than typical ABS and has higher internal damping, resulting in a rigid but acoustically “dead” baffle. Also, Noryl’s resistance to extreme heat and moisture make it an ideal choice for extreme climatic applications. Second, the cast-aluminum woofer frames were designed to enhance the structural rigidity of the entire baffle. Structural ribs on the baffle integrate with mounting bosses used to attach the cast-aluminum frame, strengthening the entire assembly and further reducing unwanted mechanical vibrations.

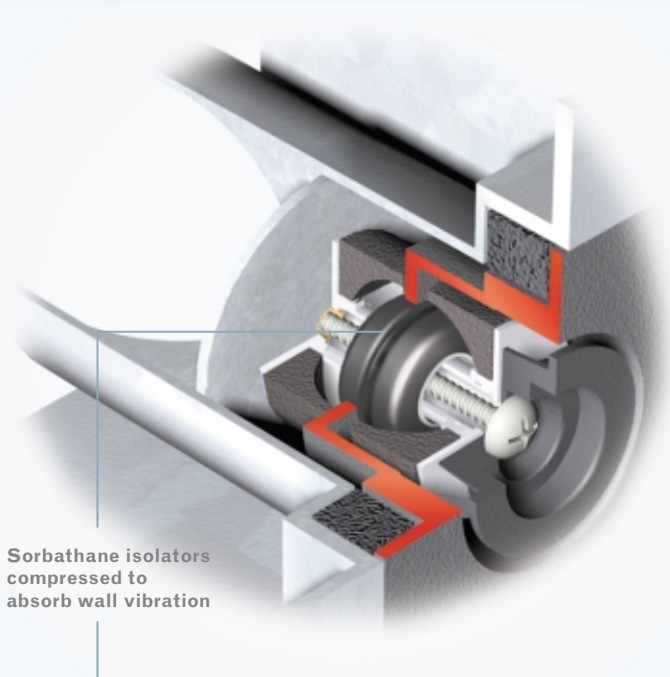

Sorbathane isolators compressed to absorb wall vibration

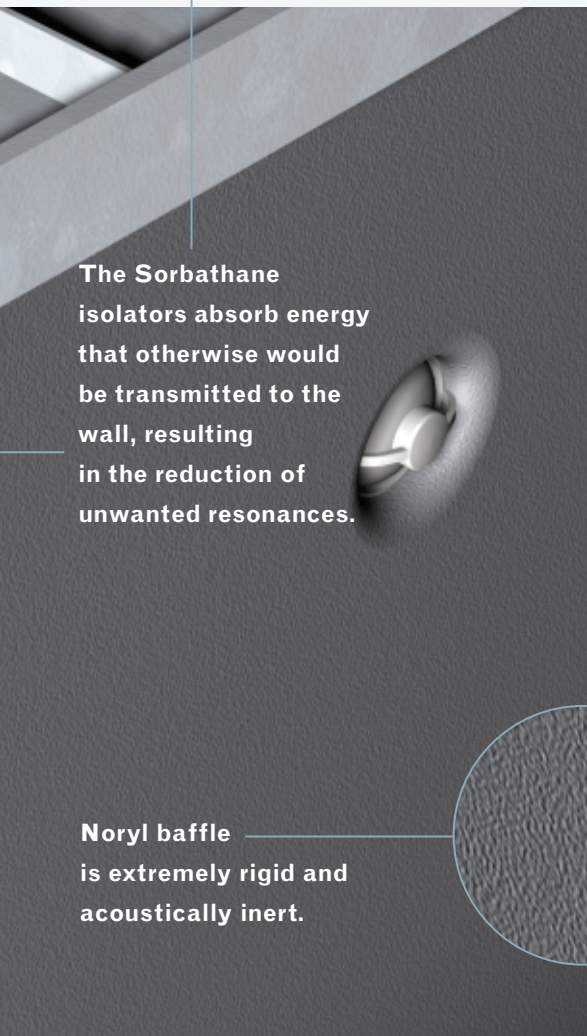

The Sorbathane isolators absorb energy that otherwise would be transmitted to the wall, resulting in the reduction of unwanted resonances.

Noryl baffle is extremely rigid and acoustically inert.

Close-up of baffle

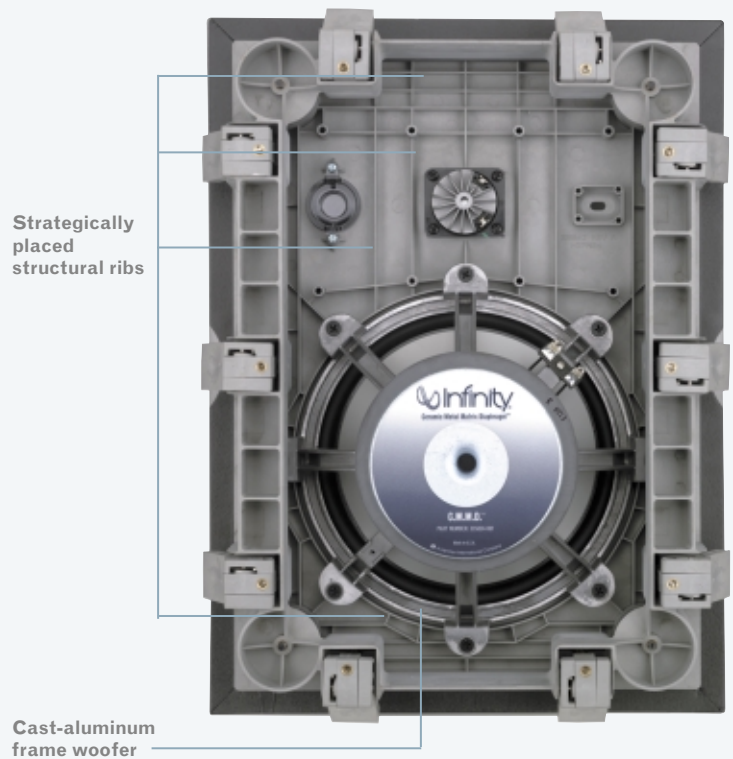

Strategically placed structural ribs

Cast-aluminum frame woofer

Figure 3: Photo of the baffle and woofer assembly. Note how the woofer bolting pattern “locks into” the baffle’s ribbing structure (crossover removed for clarity).

CERAMIC METAL MATRIX DIAPHRAGMS™ (C.M.M.D.™)

Ceramic Metal Matrix Diaphragm technology is the latest breakthrough in Infinity's 30-year history of transducer innovation. C.M.M.D. is a laminate material composed of an aluminum core and two skins of a ceramic material called "alumina." Alumina has a speed of sound twice that of aluminum and titanium, making it an ideal cone material for woofers and midranges, as well as tweeters. The breakup modes of a diaphragm made of C.M.M.D. are always well out of the operating band of the driver. For example: The first breakup mode of the CAS 3.1 midrange driver is approximately 10kHz, two full octaves above the crossover between the midrange and tweeter. This state-of-the-art midrange driver was first introduced in Infinity's critically acclaimed flagship loudspeaker, the Prelude™ MTS.

Infinity's Ceramic Metal Matrix Diaphragm material is a major breakthrough in transducer-diaphragm technology. For tweeters, it offers superior stiffness and damping compared to traditional metal domes. For woofer and midrange applications, it offers piston-like operation over the entire usable range of the driver, completely eliminating colorations due to cone modes and, thus, dramatically reducing distortion.

For more information, download our C.M.M.D. white paper from www.infinitysystems.com.

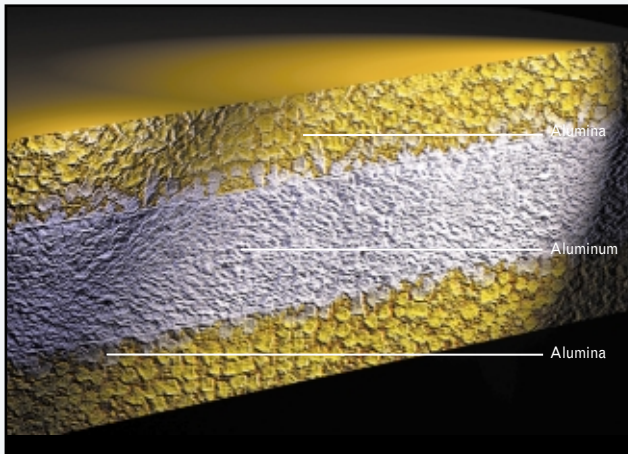

Figure 4a: An electron microscope photograph showing a cross section of a C.M.M.D. cone.

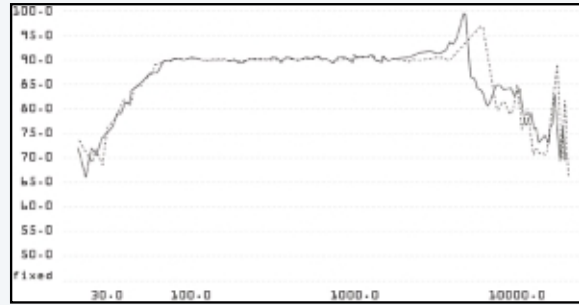

Figure 4: Frequency response of an Infinity mid-bass driver built with an aluminum cone (black curve) and C.M.M.D. cone (dotted curve). The first resonance in the C.M.M.D. cone is higher in frequency and lower in amplitude than the corresponding one in aluminum, rendering its first breakup inaudible.

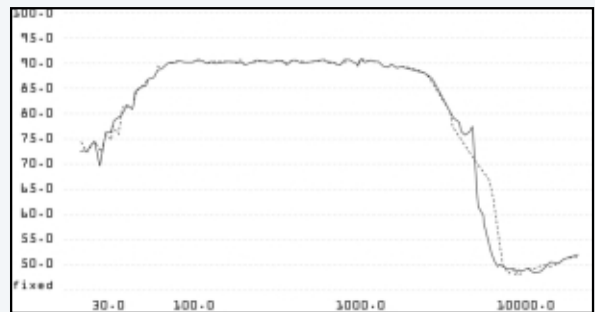

Figure 5: When the attenuation of the network is added to the curves of Figure 4, the amplitude of the first breakup mode is about 10dB lower in the C.M.M.D. cone than in the aluminum cone – this is a significant improvement. The final frequency response curve now approaches the theoretical ideal, even well beyond the crossover.

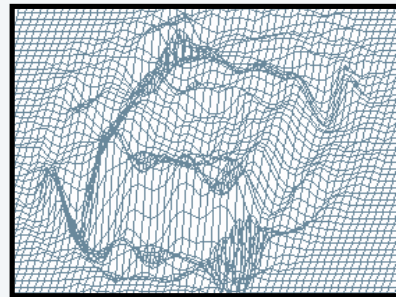

Figure 6: Scanning laser vibrometer measurement of cone movement for a Kevlar®weave cone at a frequency of 3.5kHz.

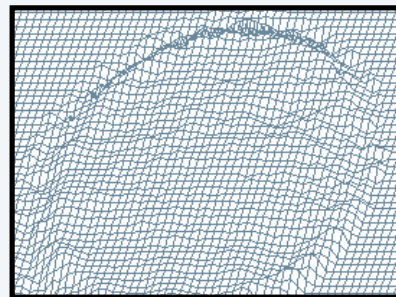

Figure 7: Scanning laser vibrometer measurement of cone movement for a C.M.M.D. cone at a frequency of 3.5kHz.

ROOM-FRIENDLY ACOUSTICAL DESIGN™

Since in-wall loudspeakers are often installed in less-than-ideal locations, using our Room-Friendly Acoustical Design will ensure that the CAS Series speakers sound superb in any listening room, from any listening position.

TWEETER WAVEGUIDES

The total sound power of a speaker is a weighted average of several frequency-response measurements made all around the loudspeaker. The difference between the on-axis response and the sound power is called the directivity of a loudspeaker. Speakers with a smooth directivity index are the ones that are the most room-friendly.

The directivity of a loudspeaker is affected by several factors, but the most important is the size of the transducer (woofer, midrange or tweeter) compared to the frequency of operation. At low frequencies the wavelengths are large relative to the size of the transducer, and the dispersion is very wide. As you move up the frequency scale the wavelengths get shorter and are eventually similar in size to the transducer reproducing the sound. At this point, the transducer starts to “beam” sound predominately straight ahead with little energy sent off-axis. The transition from wide dispersion to narrow dispersion for a single driver is very gradual, and is not a source of complaint from listeners. However, at the crossover point, dramatic differences in directivity can occur over a small frequency band, and this is a clearly audible problem. For example, in a typical two-way loudspeaker the woofer has narrow dispersion just below crossover, and just above crossover the tweeter has very wide dispersion. This results in a dip followed by a peak in the sound power that can make the speaker sound dull at times and bright at others, depending on the musical signal and the acoustics of the listening room.

To solve this problem, Infinity uses waveguides to match the directivity of the tweeter to the transducer it operates beside. The small waveguide on the CAS 3.1 matches the directivity of the tweeter

to the 3.5" midrange. The larger waveguide in the CAS 2.1 matches the directivity of the tweeter to the 7 1/2" woofer. In both systems the tweeter is the same; only the waveguide is different. Besides controlling directivity, waveguides also increase efficiency of the tweeter, which allows it to operate reliably – and with less distortion – at lower frequencies. This permits the tweeter to be crossed-over lower and results in wider, more even dispersion for the complete system.



LISTENING WINDOW SELECTOR[™]

CAS loudspeakers are the most “Room-Friendly In-Wall Loudspeakers” available. However, speaker location and listener positions vary so much that even the CAS loudspeakers may need the occasional adjustment. The CAS loudspeakers feature a Listening Window Selector. In the “Normal” position, the on-axis response of the speaker is flattest. This setting is ideal when the primary listening position is within 30 degrees of the loudspeaker’s main axis in a typical room. If the primary listening position is more than 30 degrees off-axis or the room is very “dead” acoustically, then the switch should be set to “Wide.” In this position, the total sound power is flatter at the highest frequencies. This results in a smoother, more balanced sound, regardless of where the speakers are installed or the listener is positioned.

The Listening Window Selector is one more step our engineers have taken to assure the listener of maximum performance.

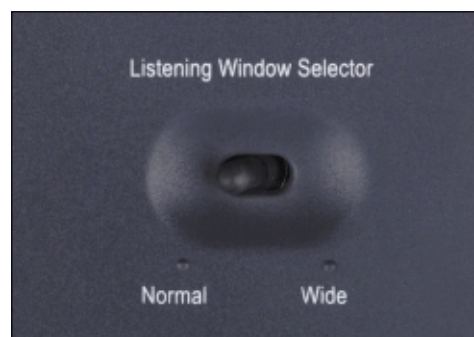

THE DETAILS . . .

HIGH-QUALITY CROSSOVER COMPONENTS

Most in-wall loudspeakers do not employ the quality crossover components commonly used in high-end loudspeakers such as the Prelude MTS. The Infinity CAS speakers are the exception. Gold-plated binding posts – which can accept 12-gauge wire – connect the high-quality circuit board to the amplifier. Only the highest quality components are used. Low-inductance resistors, polypropylene capacitors and air-core inductors are utilized for the cleanest possible sound. Finally, the network features dual sets of inputs directly connected to two independent crossover sections, allowing for bi-wiring or bi-amping.

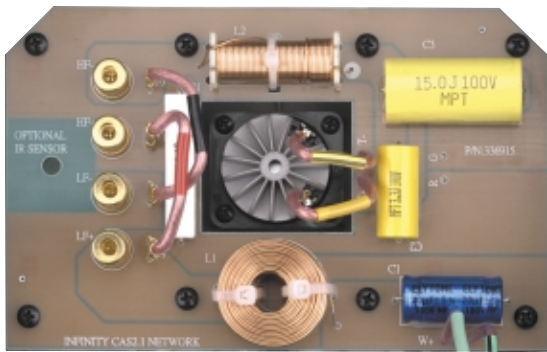

Figure 8: View of CAS 2.1 crossover.

SFG WOOFER MOTORS

Reducing resonance and improving directivity would not matter if the bass response were not clean and extended. The CAS loudspeakers feature SFG motors – just like those found on the Prelude MTS – for deep, powerful low-frequency response. SFG stands for Symmetrical Flux Geometry. An SFG motor has a symmetrical magnetic field that produces a constant driving force on the voice coil, regardless of cone position and direction of travel. This, coupled with the linear woofer suspension, creates a transducer capable of long, low-frequency excursions with minimal distortion.

NEODYMIUM MIDRANGE AND TWEETER MOTORS

Neodymium is a magnetic material that is 10 times more powerful than conventional magnets. This produces magnetic fields in small drivers, such as the midrange and tweeter in the CAS loudspeakers, of similar power to the much larger magnets typically found on woofers. As a result, tweeter and midrange efficiency is increased and distortion is reduced.

FLUSH BAFFLE

Diffraction occurs when a sound of a certain wavelength encounters a boundary, or corner, of similar size. Diffraction causes sharp dips and peaks in the frequency response both on-and off-axis. Making matters worse is the fact that these peaks and dips are different on- and off-axis, making the sound of the loudspeaker dependent on the position of the listener. The baffle of most in-wall loudspeakers is stepped back relative to the plane of the wall it is attached to, creating significant amounts of diffraction. Once installed, the baffle of the CAS loudspeaker floats on the Baffle Isolation System, flush with the wall to which it is attached, dramatically reducing diffraction.



INSTALLATION-FRIENDLY

The frame of the CAS loudspeakers features a patent-pending Spring-Loaded Mounting System.[®] A hole in the wall is cut using the supplied template. Next, the frame is temporarily held in place by the spring-loaded clamps. Once the frame is positioned properly, the mounting screws pull the clamps and frame tightly and fully – not just at the corners – against the wall for a perfectly rigid and airtight connection. The baffle assembly – including the transducers – is then mounted to the frame via the Baffle Isolation System. A damping pad (included) is placed directly behind the loudspeaker; the remainder of the wall cavity should be filled with fiberglass. No in-wall loudspeaker system is easier to install.

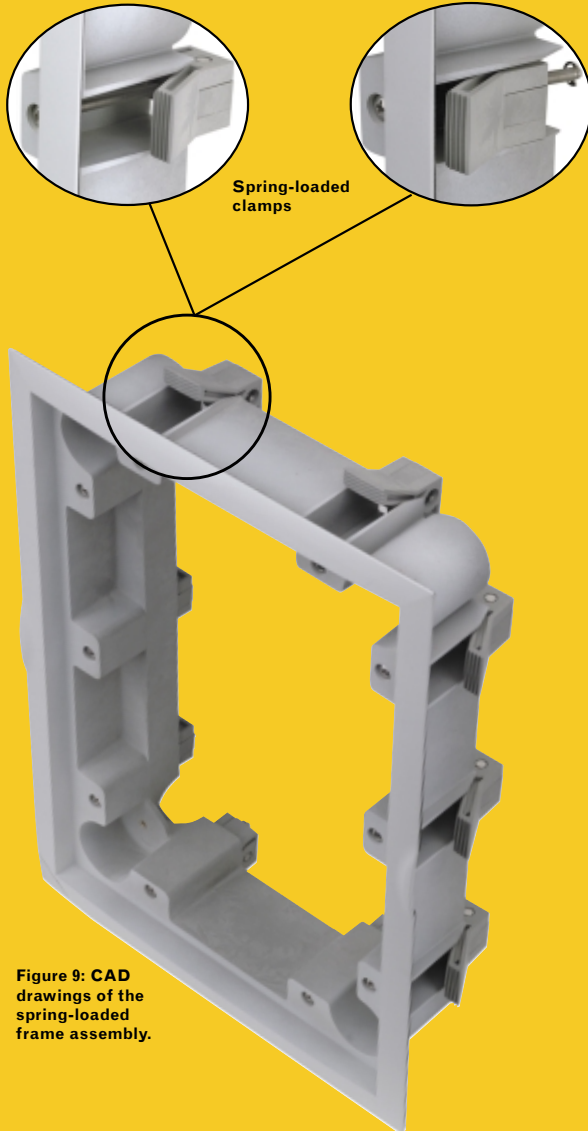

Figure 9: CAD drawings of the spring-loaded frame assembly.

Figures 10-12: Cross section of clamp assembly as the frame is inserted into the wall. Once the frame is in place, tighten the mounting screws to lock the loudspeaker into position.

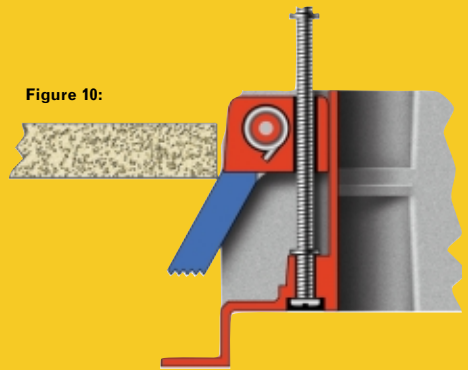

Figure 10:

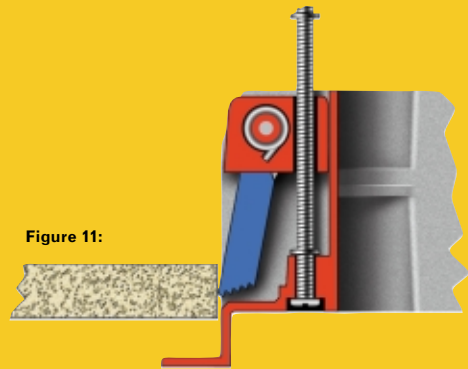

Figure 11:

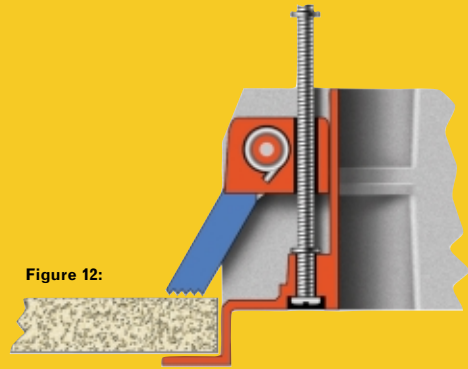

Figure 12:

The frame also features a lip that protects the transducers and the crossover from debris inside the wall. This lip, and the supplied damper pad that is placed directly behind the drivers, works with the fiberglass already in the wall to further break up standing waves in the wall cavity.

In addition, the CAS loudspeakers feature an IR lens that can accept IR repeater systems produced by several manufacturers.

SPECIFICATIONS

	CAS 3.1	CAS 2.1
Woofer:	9" C.M.M.D.	7-1/2" C.M.M.D.
Midrange:	3-1/2" C.M.M.D.	—
Tweeter:	1" C.M.M.D.	1" C.M.M.D.
System Frequency Response: (+3dB)	32Hz*–22,000Hz	40Hz*–22,000Hz
Sensitivity: (2.83V @ 1 meter)	90dB	90dB
Recommended Amplifier Power Range:	15 – 200 Watts	15 – 150 Watts
Nominal Impedance:	8 Ohms	8 Ohms
Crossover Frequency(ies):	400Hz, 2,800Hz; 24dB/octave	2,800Hz; 24dB/octave
Dimensions:		
Outer (including grille) (H x W x D)	22-1/8" x 14-7/8" x 3-1/2"*** (562mm x 378mm x 89mm)	17-7/8" x 13" x 3-1/2"*** (454mm x 330mm x 89mm)
Wall Cutout (H x W)	19-1/8" x 12-1/2" (486mm x 318mm)	14-7/8" x 10-1/2" (378mm x 267mm)
Weight: (including frame, speaker and grille)	11 lb (5kg)	15 lb (6.8kg)

*Depending upon enclosure volume. See "Enclosure Information," at right, for detailed information.

**Depth excludes grille.

THIELE/SMALL PARAMETERS

	CAS 3.1	CAS 2.1
Total Q (Q_{TS})	0.71	0.72
Compliance Volume (V_{AS})	72.3 liters	43.1 liters
Free-Air Resonance (F_S)	34.8Hz	40Hz
Mechanical Q (Q_{MS})	11.46	11.27
Electrical Q (Q_{ES})	0.76	0.77
Voice-Coil DC Resistance (R_E)	4.06 ohms	4.05 ohms
Moving Mass, Air Load (M_{MS})	34.79 grams	23.10 grams
Suspension Compliance (C_{MD})	601um/N	671um/N
Motor Force Factor (BL)	6.39 Tesla-M	5.56 Tesla-M
Driver Radiating Area (S_D)	0.0293m ²	0.0214m ²

ENCLOSURE INFORMATION

The internal volume of an enclosure is directly related to the amount of low-frequency extension and output that can be accurately reproduced by a loudspeaker. The CAS in-wall loudspeakers were designed to use the typical wall cavity dimensions of 8' x 14-1/2" x 3-1/2" for maximum low-frequency extension. However, due to varying construction standards, materials and applications, it is sometimes beneficial to create a dedicated enclosure for the speakers. The charts below show the internal volumes of sample enclosures and the resulting –3dB points for each model.

Internal Volume	CAS 3.1 –3dB Frequency	CAS 2.1 –3dB Frequency
2.7 cu. ft.	32Hz	40Hz
1.35 cu. ft.	38Hz	45Hz

It is important that the enclosures be well-constructed – MDF is recommended. The enclosure should be securely mounted to the adjacent wall studs. In addition, the enclosure should be filled with fiberglass insulation so that the enclosure is full, but the insulation is not compressed.



CAS 3.1



CAS 2.1



TECHNOLOGY • PERFORMANCE • DESIGN

■ A Harman International Company

250 Crossways Park Drive, Woodbury, NY 11797 USA • (800) 553-3332 • Fax (516) 682-3523 • www.infinitysystems.com • PART NO.: CASWHT